

Bracke M46.b

Four-row moulder

The Bracke M46.b is our most productive scarifier ever, with a working width of 8.4 m. The M46.b is the machine for you if you prioritize high production without sacrificing quality! It can be mounted on large prime movers and is suitable for both medium and large scarification sites. Thanks to its flexibility, the Bracke M46.b provides very good results on all kinds of mounding sites.

Design

The arms of the Bracke M46.b are articulated so that they give way to fixed obstacles. The outer arms have adjustable intermediate widths. To adapt to various soil conditions, Bracke M46.b can be delivered with three- or four-pointed mattock wheels. The hydraulics are load-sensing and are connected to the prime mover.

Mattock wheel

The design of the mattock wheel combined with easily replaceable tooth plates provides very good results on the planting mounds. The design of the tooth plate allows the edge to maintain its sharpness in operation and the results on the mounds are kept optimal throughout the life of the plate.

Machine control

The Bracke M46.b has its own control system, which means it can easily be installed on forwarders, regardless of make. The display makes the system very user friendly and its functions easy to understand. The moulder is fitted with sensors that send information to the operator, e.g. prime mover speed and the rate of rotation of the mattock wheels. The control system has eight programmable operating profiles. The display is used to make settings in the control system and read information from the scarifier. The control system keeps track of the number of mounds of individual sites and in total, and the number of hours worked.

Scarification

The operator controls the Bracke M46.b from the cab. Depending on changes in the site conditions, one of the preset programs are chosen. The mattock wheels are hydraulically controlled and their rate of rotation is geared to the machine's speed and the chosen operating program. The Control system enables the operator to set the Bracke M46.b to make mounds or scarify patches of varying lengths, depending on what the surroundings require. The arms can be controlled independently of each other so that they can be run as two or four rows when necessary.

Bracke Forest AB

Svedjegatan 11, SE 843 31 Bräcke, Sweden

Phone: +46 693-105 75, info@brackeforest.com, www.brackeforest.com

Technical data

Prime mover	Forwarder/skidder 18-25 ton
Weight	7 200 kg
Mattock wheels	Choice of three- or four-pointed
Mattock wheel radius	725 mm
Hydraulic pressure	160 bar
Hydraulic flow	160 l/min
Electrical system	24V
Control system	PLC based
Accessories	Seeder S35.a

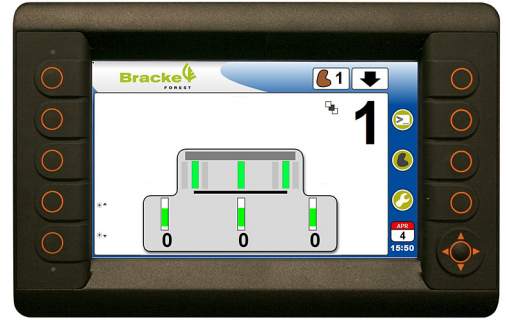

The Control system is PLC based.

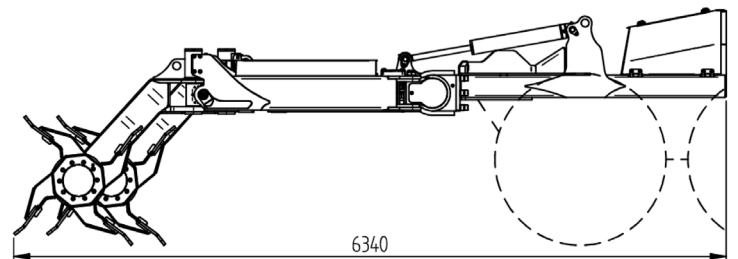
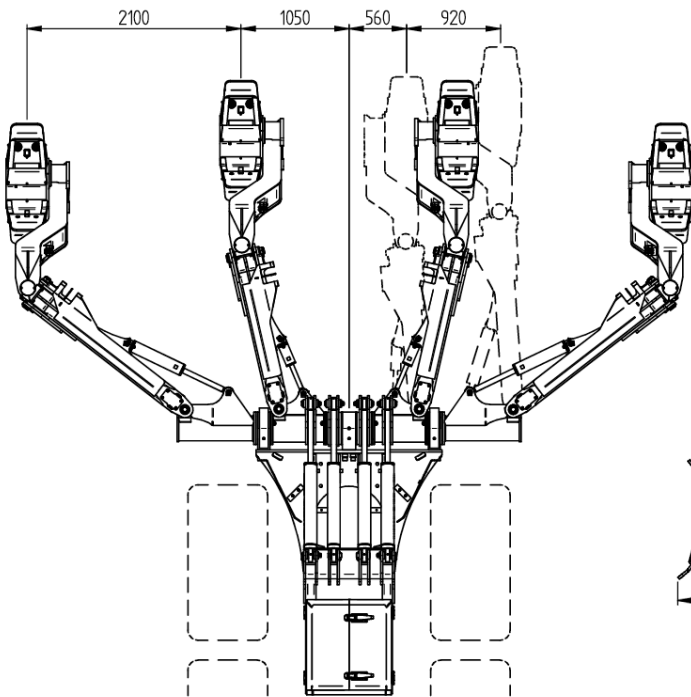

Scarification with the M46.b gives plants and seeds the best possible start for growth and survival whatever the terrain.



The Bracke M46.b creates planting spots with inverted humus (T), mineral soil mounds on inverted humus (H), and mineral soil mounds (M).

Bracke Forest AB

Svedjegatan 11, SE 843 31 Bräcke, Sweden

Phone: +46 693-105 75, info@brackeforest.com, www.brackeforest.com