

Bracke T26.b

Two-row disc trencher

The Bracke T26.b is able to handle the most troublesome terrain littered with stones and slash. Attaches to a medium-sized or large prime mover. Scarification with the Bracke T26.b gives plants and seeds the best possible start for growth and survival, whatever the terrain. Thanks to the Bracke T26.b's flexibility, it delivers good results on all types of preparation objects, but it is particularly good when terrain conditions vary greatly.

Design

The Bracke T26.b is designed to enable it to closely follow uneven terrain. The machine's hydraulics allow sideways arm movements and the disc to turn about its vertical axis if overloaded. The hydraulics are load-sensing and are connected to the prime mover.

Machine control

The control system is based on a PLC platform and communicates over the CAN bus. With the new display, the control system is very user friendly. The trencher is fitted with sensors that send information to the control system about, for example, the prime mover's speed, the disc angles and arm positions. The control system has eight programmable operating programs chosen from the controls in the cab. The display is used to make settings in the control system and read information from the trencher. The Bracke T26.b keeps track of the scarified area and distance covered, per site and in total, as well as the number of hours worked.

Scarification

The operator controls the Bracke T26.b from the cab. Depending on changes in the site conditions, one of the eight preset programs is chosen. The control system gives the operator variation possibilities to set arms and discs at different widths and angles. It is also possible to vary ground and lifting pressure or operate with float position. The Bracke T26.b can be set to work continuously or intermittently.

Bracke Forest AB

Svedjegatan 11, SE 843 31 Bräcke, Sweden

Phone: +46 693-105 75, info@brackeforest.com, www.brackeforest.com

Technical data

Prime mover	Forwarder/skidder 16–20 metric tons
Weight	3,600 kg
Disc diameter	1,000 mm, 1,400 mm incl. teeth. Replaceable teeth
Hydraulic pressure	140 bar
Hydraulic flow	100 l/min
Electrical system	24V
Control system	PLC-based
Accessories	Seeder S35.a Auxiliary oil cooler

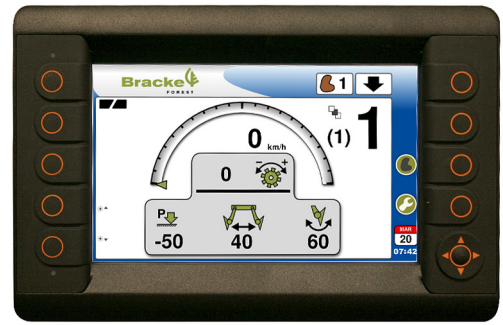

PLC-based control system.

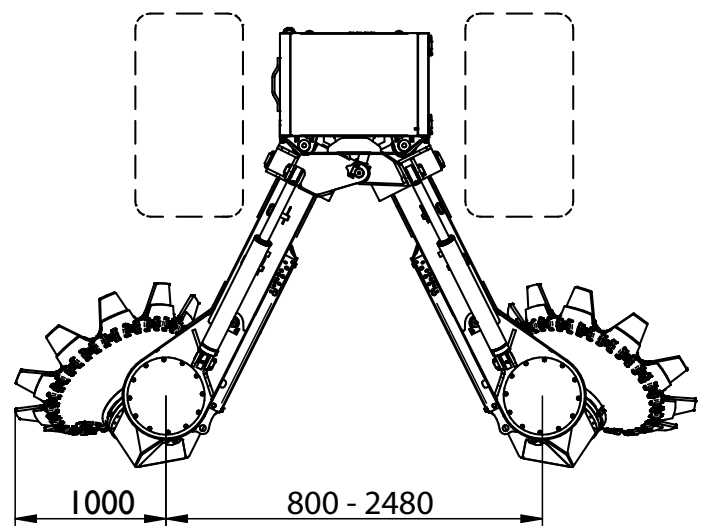
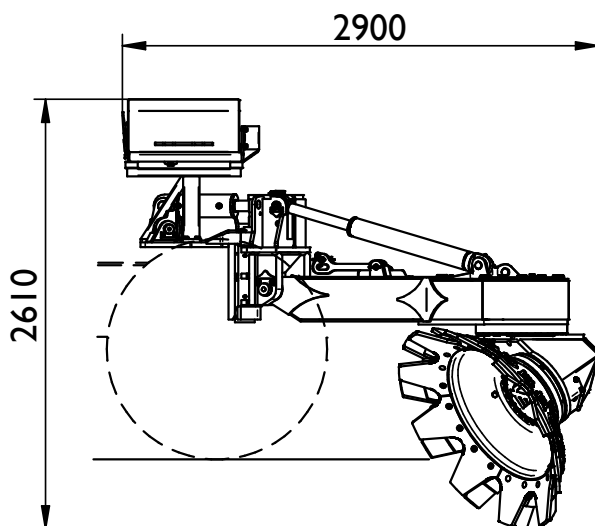

The Bracke T26.b attaches to medium-sized or large prime movers.



Discs with replaceable teeth.



The Bracke T26.b creates planting spots with inverted humus (T), mineral soil mounds on inverted humus (H), and mineral soil mounds (M).

Bracke Forest AB

Svedjegatan 11, SE 843 31 Bräcke, Sweden

Phone: +46 693-105 75, info@brackeforest.com, www.brackeforest.com